

AGRIWORLD
MOBILE DEEP
PROBE SAMPLER





MOBILE DEEP PROBE SAMPLER

Intertek is a leading testing, inspection and certification body. We offer a suite of agricultural commodity inspection services, designed to reduce the risks associated with shipping by monitoring the quality and quantity of your cargo, from source to destination.

Enhanced Agricultural Inspection Capabilities

At Intertek, we are driven by our goal to never stop innovating to better service the needs of our clients. We are proud to present our latest advance and newest addition to our dry cargo inspection capabilities – a mobile sampling device. This portable tool is a manually inserted pneumatic probe, capable of sampling to depths of 20 meters / 60 feet. It enables us to sample products which are in a static state and is ideal for taking

samples of products such as:

- **Grains and cereals:** barley, bulgur, canola, corn and corn meal, kasha, millet, oats, quinoa, rice, spelt, wheat.
- **Pulses:** lentils, dry beans, soya beans, soya meal.
- **Seeds,** such as mustard seeds.

Given its usefulness in taking samples from static products, the probe is particularly suited to assist with monitoring ground piles and silo conditions. Its time-saving, portable design makes the probe ideal for use on seagoing vessels, as well as on barges, trains, and trucks. As an example, seagoing vessels with 5 or 7 holds can now be sampled within a time frame of 12-16 hours.

Thanks to the sampler's unique design which allows samples to be taken from static product,

Intertek inspectors can eliminate unnecessary shifting, turning or related discharge activities of the product involved, thereby avoiding significant expenses and delays for our customers. Moreover, due to the portable nature of the sampler, it can be used practically anywhere throughout the European continent with a notice of 24 hours.

True to our Total Quality Assurance proposition, Intertek's new device enables us to provide the market with an easy-to-use mobile sampling tool for dry cargo which rivals current sampling capabilities for testing agricultural liquid cargo, and can help you sharpen your competitive edge.

Benefits

- Reliable, accessible and time-saving solution to check quality of a product in a static state.
- Reduces costs in your supply chain by allowing for quicker dispatch, faster delivery of analysis results and therefore a potential earlier release of goods.
- Ideally suited for taking samples of stored grain to detect issues such as salmonella, pesticides and molds.
- Suitable for nearly all grain products.
- Answers the market's needs by providing an easy-to-use, mobile means to take a full representative sample, compatible with techniques used for liquid cargo sampling.
- Intertek is the sole provider of this service solution, which is available for the EU market.

Choosing us as your inspection services partner gives you access to a global network of qualified professionals, helping you to manage risk, control quality and quantity, and comply with international standards from source to delivery. We are committed to bringing reliability, transparency and integrity to the complex and risk-prone world of cargo shipping. We take an integrated approach to inspection services, offering you traceability throughout your entire supply chain. As a global operator with over 1,000 offices and employees worldwide, as well as strong local networks, we are in a unique position to understand local challenges while also being able to apply global solutions, thereby protecting your interests all over the world.

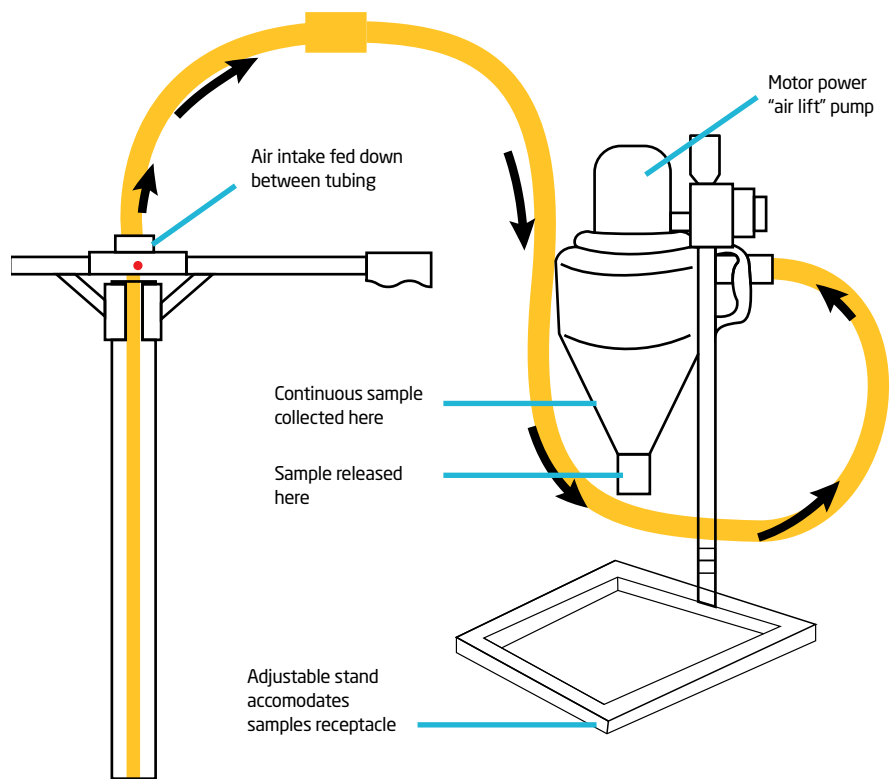



Interested to learn more about how Intertek and our new sampling device can add value to your supply chain?

PLEASE CONTACT

JOOST VAN INGEN

Manager ARA AgriWorld

 joost.vaningen@intertek.com

 +31610657120